



Avionics Databus
Solutions

APU825

USB2.0 Module
with 2 CAN bus Nodes
ARINC825 compliant
for Testing & Simulation
of Avionic ARINC825/CAN
bus Systems

Preliminary

**Data
Sheet**



APU825

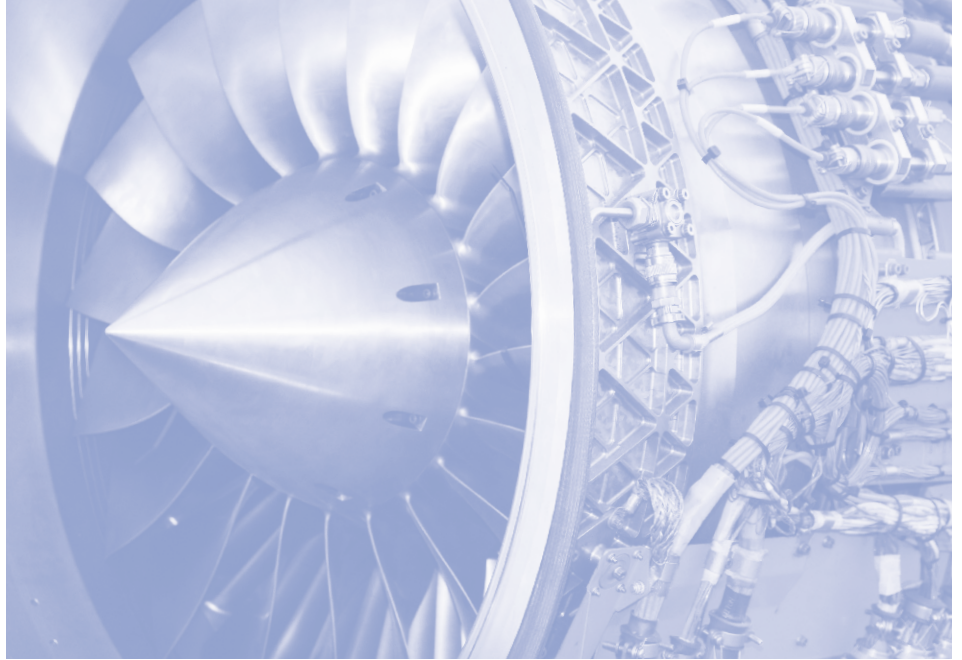

General Features

The APU825 USB2.0 Module can work as an active full functionality ARINC825/CAN node for testing and simulating applications as well as in 'listening only' mode for monitoring and recording purposes of ARINC825/CAN applications on up to 2 electrically isolated ARINC825/CAN bus nodes concurrently. All nodes are in conformance with the ISO/DIS11898-1/-2 standard. They are accessible by software separately and can be used as 2 independent ARINC825/CAN bus nodes.

An onboard IRIG-B time Decoder allows users to accurately synchronise single or multiple modules to a common time source.

All supported signals are available through Front-I/O and Rear-I/O Interface. The APU825 module consists of FPGA based ARINC825/CAN Interface Controllers as well as a FPGA based 32-bit Microcontroller Core and a separate processor for IRIG-B synchronisation with high resolution time stamping. All nodes are operating concurrently at CAN bus high speed bit rate of up to 1Mbit/s with the intelligence to process scheduling of ARINC825/CAN frames in real time onboard to significantly off-load the host processor.

The APU825 module operates also with the PBA.pro™ Databus Test & Analysis Tool for Windows.

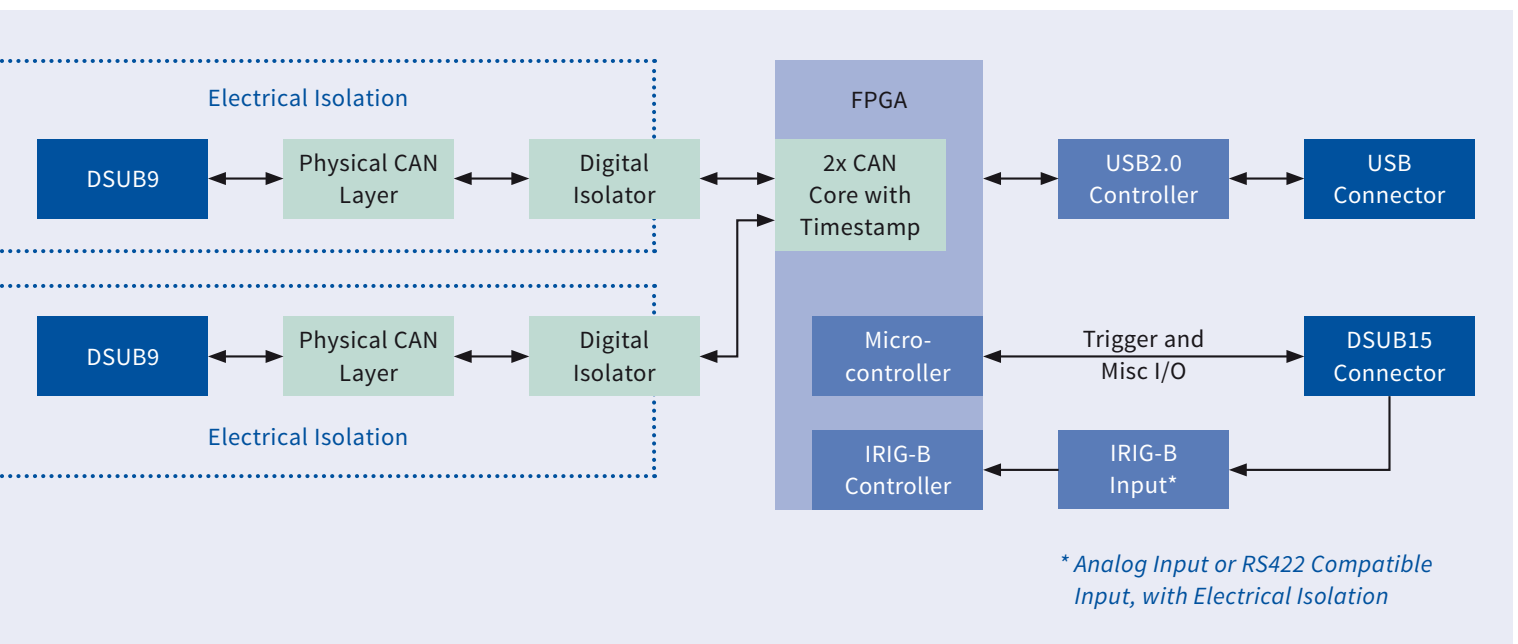

APU825 Block Diagram



ARINC825/CAN bus Channel Operation

The APU825 module provides real time simulation of up to 2 ARINC825/CAN bus nodes concurrently via FPGA based ARINC825/CAN control engine with an additional 32-bit Microcontroller. Each ARINC825/CAN bus operation speed is programmable in the range from 10kbit/s up to 1Mbit/s in accordance with the CAN 2.0B specification. Automatic baud rate detection is available. The APU825 supports the 11-bit and 29-bit message ID operation in ID oriented (Object) mode. A Listening-Only mode is available for chronological monitoring (FIFO mode).

All basic ARINC825/CAN node functions are implemented in accordance with ISO11898, CAN 2.0 A/B.

Traffic Generation

APU825 transmitter operation allows users to fully program all relevant fields of the ARINC825/CAN bus message protocol including an 11-bit or 29-bit message identifier, RTR bit, data length code and up to 8 user defined data bytes. Synchronisation of transmissions across multiple ports is supported.

- Cyclic/Acyclic ID Transmission mode
- Programmable Inter Message Timing available
- Single Shot or Automatic Retry Function if arbitration lost
- Arbitration Lost Notification
- ARINC825/CAN bus compliant Error Handling
- Message and Error Counters

Operation Modes

The APU825 module provides different operation modes for all 2 ARINC825/CAN bus nodes. The board basically supports 2 different operational modes, the Object and the FIFO mode.

In the Object mode each configured message ID has a separate buffer where message data and status information are stored in case of receiving IDs. In the Object mode, IDs can also be configured to be transmitted cyclically (scheduled transmission).

In the FIFO mode all or selected IDs are time stamped and stored in a FIFO in case of receiving IDs. The FIFO mode can be also used for transmitting IDs by passing the IDs to be sent to a transmit FIFO. In case of scheduled transmit operation the FIFO mode can be used in parallel e.g. to insert an acyclic transmission of IDs.

Independent from the selected modes above the board can be configured to operate in a Listening-Only mode which allows a passive monitoring of an ARINC825/CAN bus without disturbance of the existing traffic. Furthermore automatic handling of ARINC825/CAN RTR-Frame is supported via an Auto-Answer mode.

- Object and FIFO Transmit/Receive modes supported
- ARINC825/CAN bus Listening-Only mode for passive Monitoring
- Data Buffering with Real Time Data updates
- Scheduled Transmission of IDs
- Acyclic Transmission of IDs
- ID oriented dependent Filtering
- Time Stamping of received Frames with IRIG-B Time Code 1µs Resolution
- Auto-Answer mode for automatic RTR Frame Handling
- Physical Error Detection, Bit Error, CRC-/Format Error, Bit Stuffing Error
- Event Generation

Physical Bus Interface

The APU825 cards have integrated ARINC825/CAN bus transceivers compliant with the ISO11898-2 high speed specification. The ARINC825/CAN bus interfaces are electrically isolated by default. All 2 ARINC825/CAN nodes are available at the Front-I/O provided at 2x9-way D-Sub (male) connector.

IRIG-B Time Decoder

APU825 cards have an onboard IRIG-B Time Decoder with 1µs resolution and an automatic free wheeling detection. This allows synchronisation of multiple APU825 cards to 1 common IRIG-B time source for the correlation of data across multiple ARINC825/CAN bus nodes.

Driver Software

The APU825 modules are supplied with an Application Programming Interface (API) and Driver Software compatible with Windows.

Application Software

An ARINC825 Resource Component is available for AIM's PBA.pro™ Databus Test & Analysis Tool including Tx and Rx simulation capabilities, a Chronological Bus Monitor and support for decoding of payload data within ARINC825/CAN messages. This allows to implement a powerful ARINC825/CAN bus Analyser or a complete Test System in conjunction with other AIM Avionics Databus Interfaces and PBA.pro™ supported 3rd party hardware.

Technical Data

System Interface

USB2.0 Interface: 480Mbit USB2.0 Standard Interface

Processors

FPGA based 32-bit Microcontroller Core

Encoder/Decoder

FPGA based CAN 2.0 A/B bus Controller Core

Time Tagging

46-bit absolute IRIG-B Time Code, 1µs resolution; free wheeling

Physical Bus Interface

2x ISO11898-2 compliant high speed Transceivers; each ARINC825/CAN bus node is electrically isolated

Front-I/O Interface Connector

- 2x 9-way D-Sub (male), providing 2 independent electrically isolated ARINC825/CAN bus nodes (with CiA Pinout)
- 1x 15-way D-Sub (female), providing IRIG-B Time Code Input (analogue IRIG-B and RS422), Trigger-I/O

USB2.0/PCI Interface Connector

USB2.0 B type connector

Dimensions

86mm x 19mm x 86mm

Operating Temperature Range

Standard: 0°C to +50°C ambient

Ordering Information

APU825

USB2.0 to ARINC825 Module with 2 ARINC825/CAN bus nodes, IRIG-B Time Decoder, including USB Cable (occupying 1 USB Port)

AIM Office Contacts:

AIM GmbH

Sasbacher Str. 2
D-79111 Freiburg / Germany
Phone +49 (0)761 4 52 29-0
Fax +49 (0)761 4 52 29-33
sales@aim-online.com

AIM GmbH – Munich Sales Office

Terofalstr. 23a
D-80689 München / Germany
Phone +49 (0)89 70 92 92-92
Fax +49 (0)89 70 92 92-94
salesgermany@aim-online.com

AIM UK Office

Cressex Enterprise Centre, Lincoln Rd.
High Wycombe, Bucks. HP12 3RB / UK
Phone +44 (0)1494-446844
Fax +44 (0)1494-449324
salesuk@aim-online.com

AIM USA LLC

Seven Neshaminy Interplex
Suite 211 Trevoise, PA 19053
Phone 267-982-2600
Fax 215-645-1580
salesusa@aim-online.com