

Quality is more than a word

ESPEC

Temperature Cycling Chambers

Global-N Series



ESPEC NORTH AMERICA, INC

Faster test chambers ...

The Global-N series chambers from ESPEC provide the temperature cycling and humidity performance you need to validate quality and reliability for increasingly sophisticated electronics and other products.



28 cu. ft.



12 cu. ft.



4 cu. ft.

Global Features

World-standard performance and features on a minimal footprint

The Global-N chambers have temperature change rates from 5 to 30°C per minute. In addition, controlled humidity from 10 to 95% is an available feature. There are five sizes, including our newest and smallest size 4 cu.ft. (114L) They are compact, requiring the least amount of floor space for this level of performance.

These chambers feature the classic ESPEC look of stainless steel with a modern style. The control console is on the door, making the footprint of the unit even more compact. A simple, but secure, door latch is easier than ever to use.

International applications

Global-N chambers meet Mil-Std, JEDEC, IEC, and other international test performance standards. The units can be installed around the world for consistent testing at different facilities, supported by your local ESPEC service group.

Designed for serviceability and safety

For safety and worldwide compliance, Global-N series are UL 508A certified or CE-marked.

The refrigeration service panels are hinged for fast access. Analog refrigeration gauges help you monitor system performance and pinpoint service needs.

Standard features:

- Stainless steel exterior and interior
- High performance refrigeration utilizing reliable Scroll compressors (except -15WW models)
- Hinged service panels for easy access
- Unique non-metallic thermal breaks around the door-frame and cable ports
- Specimen power relay for interlocking test samples or external devices to chamber power for safety
- One 4" (100mm) cable port, one shelf & casters included

Controller features:

- ESPEC Web Controller touch-screen interface with 10-inch display for programming, monitor, and datalogging
- Program up to 40 test profiles, each with up to 50 steps each (ramp, soak, jump) (via on-board Watlow F4T)
- Two event relays for external device control
- Remote access via LAN/Ethernet, with email alerts, macros, & API



Innovative high-speed airflow suited for fast temperature cycling applications.



Advanced refrigeration design is especially compact for high performance test chambers.

Performance

Temperature cycling up to 30 degrees per minute

Global-N series has more than twenty different models to allow you to choose the size and performance best suited for your test applications. Temperature cycling rates from 5 to 30°C/min. are possible. Two different ultimate low temperatures are available: -35°C or -70°C.

Models EGNL & EGNX also control humidity, for expanded testing options beyond temperature cycling.

Global-N chambers are capable of meeting the performance requirements of JEDEC, IEC, Mil-Std, and other international environmental test performance standards.

Get a performance evaluation to help select your model

For better assurance of performance for your temperature cycling application, ESPEC can provide a guaranteed performance calculation based on your submitted requirements.

Please use these questions (at right) as a guide to define your test plan. You can then give this information to your local sales representative, or submit at www.espec.com, for review by an ESPEC engineer. A recommended model with appropriate refrigeration size will be returned.

Air-cooled models available

High performance test chambers usually mean water cooling utilities are required. Global-N models with 4 or 6-hp refrigeration are available with integrated air-cooling. The condenser is mounted on top with low-speed fans for minimal noise impact.

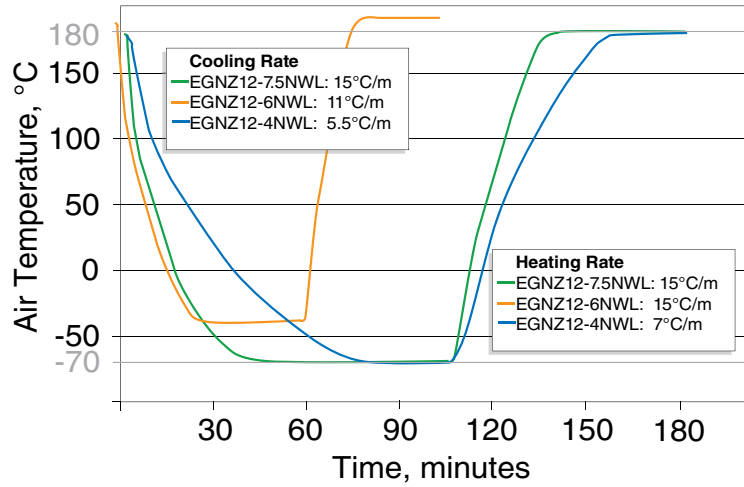

Different Global-N models can heat and cool at different rates. Shown above are change rates for EGNZ12 models, following IEC 60068 3-5 standard, with the sensor in the supply air.

Questions for performance evaluation request:

1. Chamber type

Desired size: 4, 12, 16, 28, or 35 cu. ft.? (114, 380, 470, 800, or 1000 L?)

Local power: 60Hz or 50Hz?

Humidity control: Yes or no?

2. Your Sample

Sample description and type of material(s)

Total mass per test, including any racks or cabling

Heat output of samples, in watts, if powered during test

3. Your Test Plan

Test method, if a published standard (e.g. JEDEC JESD22-A104C)

Start temperature for cycling

End temperature for cycling

Ramp rate or time allowed between start and end temperatures

Ramp rate measured in the air or on the product



Air-cooled condenser on top of the chamber saves utility and installation cost. Adds 14" (350mm) to the exterior height.

Advanced Control



The door-mounted console includes the P-300 programmer, USB port, product temperature protector, and chamber light (option).

Enhanced performance and USB access with P-300 touch-screen controller

The exclusive ESPEC P-300 programmer/controller brings energy savings, user-friendly operation, and expanded data access to the Global-N chambers. Tabs on the updated user interface allow faster access to any screen. Standard USB and optional Ethernet interfaces make programming and data acquisition much simpler. In addition, improved algorithms make operation more energy efficient, as well as faster and smoother.

- Store up to forty programs, as well as three constant-mode configurations.
- Multilingual display in English, Japanese, Chinese, or Korean.
- Alarm history and diagnostics, plus a "back trace" feature for troubleshooting.

Sophisticated future-looking algorithms make temperature ramping faster and smoother. They also improve energy efficiency and make tests more repeatable.

Standard USB port for upload/download of programs and test data. Test programs can be edited and stored on a PC using included software, then uploaded via USB. Operation data can be downloaded for review, graphing, or exporting to Excel.

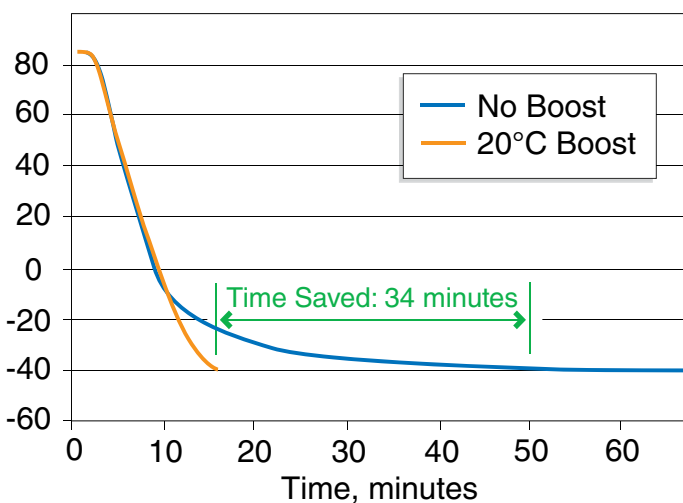

Product temperature control generates faster ramp-rates for test samples, as well as significant time savings for soak periods.

Optional product temperature control

- Monitors product temperature
- Enables faster product change rates
- Shortens testing time

During normal cycling tests, product temperature can lag behind air temperatures by up to 20 degrees. The optional product temperature control is a valuable feature for high performance testing in Global-N chambers. This feature drives faster change rates by directly monitoring product temperature and automatically boosting air-temperature setpoints until the sample approaches the desired temperature.

As shown in the example at left, achieving -40°C product temperature with a 20°C boost (air overshooting temporarily to -60°C) took just 16 minutes, compared for nearly 50 minutes with the chamber air set at -40°C.

SPECIFICATION - 4 CU. FT./ 114 L MODELS

RANGE -65 TO 180°C Temp-only

EGNZ4-5NWL	
Temperature Range	-65 to 180°C (-85 to 354°F)
Cooling Capacity	2.5 kW [2 kW] at -60°C
Refrigeration System	Cascade 5 hp Scroll
Heating System	7 kW
Measured Airflow	300 CFM (510 cubic meters per hour)
Performance Example (-70°C to 180°C, per IEC 60068 3-5, at supply air)	
Heating Rate	30°C/m
Cooling Rate	25°C/m [20°C/m]
Site Requirements	
Power Supply	460V 3Ø 60Hz [380-415V 3Ø 50Hz]
Recommended Service	40 A [40 A]
Cooling Water Maximum with 30°C Inlet	42 LPM (11 GPM)

*Cooling capacity, ramp rates, and service amps in brackets are for 380-415V 50Hz power.

DIMENSIONS - 4 cu. ft. models

Workspace Volume	4 cu. ft. (114 L)
Workspace (WxDxH)	19.6" x 15" x 23.6" (498 x 381 x 600 mm)
Exterior (WxDxH)	30" x 82.6" x 75" (770 x 1427 x 1905 mm)



4 cu. ft. model

SPECIFICATION NOTES:

- Please submit a performance evaluation request (see page 4) to ensure selection of the correct model for your test requirement.
- Cooling water requirements listed are maximum. Actual water demand varies with cooling demand and water temperature. Detailed cooling water demand charts are available.
- Site requirements also include a drain for condensate water from the chamber, and ample spacing for service and proper ventilation.
- These specifications are for reference only. Detailed and current specifications can be obtained from your sales representative or at espec.com.

SPECIFICATION - 12 CU. FT. / 380 L MODELS

RANGE -70 TO 180°C Temp-only

	EGNZ12-4NWL EGNZ12-4NAL	EGNZ12-6NWL EGNZ12-6NAL	EGNZ12-7.5NWL
Temperature Range	-70 to 180°C (-94 to 354°F)		
*Cooling Capacity	2.5 kW [2 kW] at -50°C	3.6 kW [3 kW] at -50°C	4 kW [3.3 kW] at -50°C
Refrigeration System	Cascade 4 hp Scroll	Cascade 6 hp Scroll	Cascade 7.5 hp Scroll
Heating System	5 kW	8 kW	10 kW
Measured Airflow	500 CFM (850 cubic meters per hour)		
Performance Example (-70°C to 180°C, per IEC 60068 3-5, at supply air)			
*Heating Rate	7°C/m	14°C/m	15°C/m
*Cooling Rate	6.5°C/m [6°C/m]	11°C/m [10.5°C/m]	16°C/m [15°C/m]
Site Requirements			
Electrical Supply	460V 3Ø 60Hz [380-415V 3Ø 50Hz]		
*Recommended Service	35 A [35 A]	40 A [45 A]	45 A [50 A]
Cooling Water Maximum with 30°C Inlet	9 GPM (34 LPM) (NWL suffix models)	14 GPM (53 LPM) (NWL suffix models)	19 GPM (72 LPM)
Heat to Room	40,000 BTU/hr (NAL suffix models)	60,000 BTU/hr (NAL suffix models)	—

*Cooling capacity, ramp rates, and service amps in brackets are for 380V-415V 50Hz power.

DIMENSIONS - 12 cu. ft. models

Workspace Volume	12 cu. ft. (380 L)	
Workspace (WxDxH)	23.6" x 29.25" x 33.5" (600 x 743 x 850 mm)	
Exterior (WxDxH)	NWL suffix models	35" x 83" x 70" (889 x 2103 x 1768 mm)
	NAL suffix models	35" x 83" x 84" (889 x 2103 x 2129 mm)



12 cu. ft. model
(page 7 & 8)

SPECIFICATION - 12 CU. FT. / 380 L MODELS

RANGE -70 TO 180°C Temp/Humidity

	EGNX12-4NWL EGNX12-4NAL	EGNX12-6NWL EGNX12-6NAL	EGNX12-7.5NWL
Temperature Range	-70 to 180°C (-94 to 354°F)		
*Cooling Capacity	2.5 kW [2 kW] at -50°C	3.6 kW [3 kW] at -50°C	4 kW [3.3 kW] at -50°C
Refrigeration System	Cascade 4 hp Scroll	Cascade 6 hp Scroll	Cascade 7.5 hp Scroll
Heating System	5 kW	8 kW	10 kW
Humidity Range	10 to 95% RH per chart below		
Measured Airflow	500 CFM (850 cubic meters per hour)		
Performance Example (-70°C to 180°C, per IEC 60068 3-5, at supply air)			
*Heating Rate	7°C/m	14°C/m	15°C/m
*Cooling Rate	6.5°C/m [6°C/m]	11°C/m [10.5°C/m]	16°C/m [15°C/m]
Site Requirements			
Electrical Supply	460V 3Ø 60Hz [380-415V 3Ø 50Hz]		
*Recommended Service	35 A [35 A]	40 A [45 A]	45 A [50 A]
Humidity Water	De-ionized water, 0.2 to 10 µS/cm resistivity		
Cooling Water Maximum with 30°C Inlet	9 GPM (34 LPM) (NWL suffix models)	14 GPM (53 LPM) (NWL suffix models)	19 GPM (72 LPM)
Heat to Room	40,000 BTU/hr (NAL suffix models)	60,000 BTU/hr (NAL suffix models)	—

*Cooling capacity, ramp rates, and service amps in brackets are for 380V-415V 50Hz power.

RANGE -40 TO 180°C Temp/Humidity & Temp-only

	EGNL12-4NWL EGNL12-4NAL	EGNL12-6NWL EGNL12-6NAL	EGNU12-4NWL EGNU12-4NAL	EGNU12-6NWL EGNU12-6NAL
Temperature Range	-40 to 180°C (-40 to 354°F)			
*Cooling Capacity	3.3 kW [2.8 kW] at -20°C	4.3 kW [3.6 kW] at -20°C	3.3 kW [2.8 kW] at -20°C	4.3 kW [3.6 kW] at -20°C
Refrigeration System	Single-stage 4 hp Scroll	Single-stage 6 hp Scroll	Single-stage 4 hp Scroll	Single-stage 6 hp Scroll
Heating System	5 kW	8 kW	5 kW	8 kW
Humidity Range	10 to 95% RH per chart below		—	
Measured Airflow	500 CFM (850 cubic meters per hour)			
Performance Example (-40°C to 180°C, per IEC 60068 3-5, at supply air)				
*Heating Rate	8°C/m	15°C/m	8°C/m	15°C/m
*Cooling Rate	9°C/m [8°C/m]	13°C/m [12°C/m]	9°C/m [8°C/m]	13°C/m [12°C/m]
Site Requirements				
Electrical Supply	460V 3Ø 60Hz [380-415V 3Ø 50Hz]			
*Recommended Service	30 A [30 A]	35 A [40 A]	25 A [30 A]	35 A [35 A]
Humidity Water	De-ionized water, 0.2 to 10 µS/cm resistivity		—	
Cooling Water Maximum with 30°C Inlet	9 GPM (35 LPM) (NWL suffix models)	14 GPM (55 LPM)	9 GPM (35 LPM) (NWL suffix models)	14 GPM (55 LPM) (NWL suffix models)
Heat to Room	52,000 BTU/hr (NAL suffix models)	—	52,000 BTU/hr (NAL suffix models)	75,000 BTU/hr (NAL suffix models)

*Cooling capacity, ramp rates, and service amps in brackets are for 380V-415V 50Hz power.

Humidity Control Range

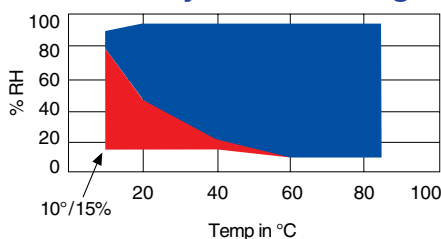

For EGNL & EGNX models:

Blue = Standard humidity range
Red = Optional low-humidity range

Guaranteed humidity control range without live load.
Fluctuation is within ±3%, per IEC 60068 3-6.

SPECIFICATION - 16 CU. FT. / 470 L MODELS

RANGE -70 TO 180°C Temp-only

	EGNZ16-4NWL EGNZ16-4NAL	EGNZ16-6NWL EGNZ16-6NAL	EGNZ16-7.5NWL
Temperature Range	-70 to 180°C (-94 to 354°F)		
*Cooling Capacity	2.1 kW [2 kW] at -50°C	3.2 kW [3 kW] at -50°C	3.8 kW [3.3 kW] at -50°C
Refrigeration System	Cascade 4 hp Scroll	Cascade 6 hp Scroll	Cascade 7.5 hp Scroll
Heating System	5 kW	8 kW	10 kW
Measured Airflow	500 CFM (850 cubic meters per hour)		
Performance Example (-70°C to 180°C, per IEC 60068 3-5, at supply air)			
*Heating Rate	6°C/m	13°C/m	15°C/m
*Cooling Rate	5.5°C/m [5°C/m]	10.5°C/m [10°C/m]	15.5°C/m [15°C/m]
Site Requirements			
Electrical Supply	460V 3Ø 60Hz [380-415V 3Ø 50Hz]		
*Recommended Service	35 A [35 A]	40 A [45 A]	45 A [50 A]
Cooling Water Maximum with 30°C Inlet	9 GPM (34 LPM) (NWL suffix models)	14 GPM (53 LPM) (NWL suffix models)	19 GPM (72 LPM)
Heat to Room	40,000 BTU/hr (NAL suffix models)	60,000 BTU/hr (NAL suffix models)	—

*Cooling capacity, ramp rates, and service amps in brackets are for 380V-415V 50Hz power.

RANGE -70 TO 180°C Temp/Humidity

	EGNX16-4NWL EGNX16-4NAL	EGNX16-6NWL EGNX16-6NAL	EGNX16-7.5NWL
Temperature Range	-70 to 180°C (-94 to 354°F)		
*Cooling Capacity	2.1 kW [2 kW] at -50°C	3.2 kW [3 kW] at -50°C	3.8 kW [3.3 kW] at -50°C
Refrigeration System	Cascade 4 hp Scroll	Cascade 6 hp Scroll	Cascade 7.5 hp Scroll
Heating System	5 kW	8 kW	10 kW
Humidity Range	10 to 95% RH per chart below		
Measured Airflow	500 CFM (850 cubic meters per hour)		
Performance Example (-70°C to 180°C, per IEC 60068 3-5, at supply air)			
*Heating Rate	6°C/m	13°C/m	15°C/m
*Cooling Rate	5.5°C/m [5°C/m]	10.5°C/m [10°C/m]	15.5°C/m [15°C/m]
Site Requirements			
Electrical Supply	460V 3Ø 60Hz [380-415V 3Ø 50Hz]		
*Recommended Service	35 A [35 A]	40 A [45 A]	45 A [50 A]
Humidity Water	De-ionized water, 0.2 to 10 µS/cm resistivity		
Cooling Water Maximum with 30°C Inlet	9 GPM (34 LPM) (NWL suffix models)	14 GPM (53 LPM) (NWL suffix models)	19 GPM (72 LPM)
Heat to Room	40,000 BTU/hr (NAL suffix models)	60,000 BTU/hr (NAL suffix models)	—

*Cooling capacity, ramp rates, and service amps in brackets are for 380V-415V 50Hz power.

DIMENSIONS - 16 cu. ft. models

Workspace Volume	16 cu. ft. (470L)	
Workspace (WxDxH)	29.5" x 29.2" x 33.5" (749 x 743 x 850 mm)	
Exterior (WxDxH)	NWL suffix models	40.9" x 82.6" x 69.6" (1038 x 2089 x 1768 mm)
	NAL suffix models	40.9" x 82.9" x 83.8" (1038 x 2106 x 2129 mm)

Humidity Control Range

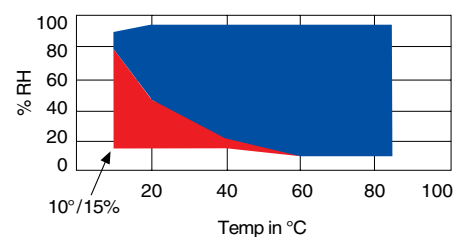

For EGNL & EGNX models:

Blue = Standard humidity range
Red = Optional low-humidity range

Guaranteed humidity control range without live load.
Fluctuation is within ±3%, per IEC 60068 3-6.

SPECIFICATION - 28 CU. FT. / 800L MODELS

RANGE -70 TO 180°C Temp-only

	EGNZ28-4NWL EGNZ28-4NAL	EGNZ28-6NWL EGNZ28-6NAL	EGNZ28-12NWL	EGNZ28-15NW
Temperature Range	-70 to 180°C (-94 to 354°F)			
*Cooling Capacity	2.5 kW [2 kW] at -50°C	3.6 kW [3 kW] at -50°C	5 kW [4.2 kW] at -50°C	9.4 kW [7.8 kW] at -50°C
Refrigeration System	Cascade 4 hp Scroll	Cascade 6 hp Scroll	Cascade 12 hp Scroll	Cascade 15 hp Discus
Heating System	10 kW	10 kW	15 kW	20 kW
Measured Airflow	800 CFM (1,350 cubic meters per hour)			
Performance Example (-70°C to 180°C, per IEC 60068 3-5, at supply air)				
*Heating Rate	10°C/m	10°C/m	15°C/m	20°C/m
*Cooling Rate	3°C/m [2.75°C/m]	6°C/m [5.5°C/m]	13.5°C/m [12.5°C/m]	20°C/m [20°C/m]
Site Requirements				
Electrical Supply	460V 3Ø 60Hz [380-415V 3Ø 50Hz]			
*Recommended Service	40 A [45 A]	45 A [50 A]	70 A [80 A]	100 A [100 A]
Cooling Water Maximum with 30°C Inlet	9 GPM (34 LPM) (NWL suffix models)	14 GPM (53 LPM) (NWL suffix models)	27 GPM (102 LPM)	32 GPM (121 LPM)
Heat to Room	40,000 BTU/hr (NAL suffix models)	60,000 BTU/hr (NAL suffix models)	—	—

*Cooling capacity, ramp rates, and service amps in brackets are for 380V-415V 50Hz power.

RANGE -40 TO 180°C Temp-only

	EGNU28-4NWL EGNU28-4NAL	EGNU28-6NWL EGNU28-6NAL	EGNU28-7.5NWL	EGNU28-12NWL
Temperature Range	-40 to 180°C (-40 to 354°F)			
*Cooling Capacity	3.3 kW [2.8 kW] at -20°C	4.3 kW [3.6 kW] at -20°C	5.2 kW [4.3 kW] at -20°C	10.5 kW [8.8 kW] at -20°C
Refrigeration System	Single-stage 4 hp Scroll	Single-stage 6 hp Scroll	Single-stage 7.5 hp Scroll	Single-stage 12 hp Scroll
Heating System	10 kW	10 kW	15 kW	15 kW
Measured Airflow	800 CFM (1,350 cubic meters per hour)			
Performance Example (-40°C to 180°C, per IEC 60068 3-5, at supply air)				
*Heating Rate	10°C/m	10°C/m	15°C/m	15°C/m
*Cooling Rate	5°C/m [4°C/m]	9°C/m [8°C/m]	13°C/m [12°C/m]	16°C/m [15°C/m]
Site Requirements				
Electrical Supply	460V 3Ø 60Hz [380-415V 3Ø 50Hz]			
*Recommended Service	30 A [35 A]	35 A [40 A]	60 A [60 A]	60 A [60 A]
Cooling Water Maximum with 30°C Inlet	9 GPM (35 LPM) (NWL suffix models)	14 GPM (55 LPM) (NWL suffix models)	19 GPM (79 LPM)	27 GPM (106 LPM)
Heat to Room	52,000 BTU/hr (NAL suffix models)	75,000 BTU/hr (NAL suffix models)	—	—

*Cooling capacity, ramp rates, and service amps in brackets are for 380V-415V 50Hz power.

DIMENSIONS - 28 cu. ft. models

Workspace Volume	28 cu. ft. (800 L)	
Workspace (WxDxH)	39.4" x 31.5" x 39.4" (1000 x 800 x 1000 mm)	
Exterior (WxDxH)	NWL suffix models	51" x 85" x 76" (1290 x 2159 x 1920 mm)
	NAL suffix models	51" x 85" x 90" (1290 x 2159 x 2280 mm)
	NW suffix models	51" x 121" x 79.5" (1290 x 3074 x 2014 mm)



28 cu. ft. model
(page 10 & 11)

SPECIFICATION - 28 CU. FT. / 800L MODELS

RANGE -70 TO 180°C Temp/Humidity

	EGNX28-4NWL EGNX28-4NAL	EGNX28-6NWL EGNX28-6NAL	EGNX28-12NWL	EGNX28-15NW
Temperature Range	-70 to 180°C (-94 to 354°F)			
*Cooling Capacity	2.5 kW [2 kW] at -50°C	3.6 kW [3 kW] at -50°C	5 kW [4.2 kW] at -50°C	9.4 kW [7.8 kW] at -50°C
Refrigeration System	Cascade 4 hp Scroll	Cascade 6 hp Scroll	Cascade 12 hp Scroll	Cascade 15 hp Discus
Heating System	10 kW	10 kW	15 kW	20 kW
Humidity Range	10 to 95% RH per chart below			
Measured Airflow	800 CFM (1,350 cubic meters per hour)			
Performance Example (-70°C to 180°C, per IEC 60068 3-5, at supply air)				
*Heating Rate	10°C/m	10°C/m	15°C/m	20°C/m
*Cooling Rate	3°C/m [2.75°C/m]	6°C/m [5.5°C/m]	13.5°C/m [12.5°C/m]	20°C/m [20°C/m]
Site Requirements				
Electrical Supply	460V 3Ø 60Hz [380-415V 3Ø 50Hz]			
*Recommended Service	45 A [45 A]	45 A [50 A]	70 A [80 A]	100 A [100 A]
Humidity Water	De-ionized water, 0.2 to 10 µS/cm resistivity			
Cooling Water Maximum with 30°C Inlet	9 GPM (34 LPM) (NWL suffix models)	14 GPM (53 LPM) (NWL suffix models)	27 GPM (102 LPM)	32 GPM (121 LPM)
Heat to Room	40,000 BTU/hr (NAL suffix models)	60,000 BTU/hr (NAL suffix models)	—	—

*Cooling capacity, ramp rates, and service amps in brackets are for 380V-415V 50Hz power.

RANGE -40 TO 180°C Temp/Humidity

	EGNL28-4NWL EGNL28-4NAL	EGNL28-6NWL EGNL28-6NAL	EGNL28-7.5NWL	EGNL28-12NWL
Temperature Range	-40 to 180°C (-40 to 354°F)			
*Cooling Capacity	3.3 kW [2.8 kW] at -20°C	4.3 kW [3.6 kW] at -20°C	5.2 kW [4.3 kW] at -20°C	10.5 kW [8.8 kW] at -20°C
Refrigeration System	Single-stage 4 hp Scroll	Single-stage 6 hp Scroll	Single-stage 7.5 hp Scroll	Single-stage 12 hp Scroll
Heating System	10 kW	10 kW	15 kW	15 kW
Humidity Range	10 to 95% RH per chart below			
Measured Airflow	800 CFM (1,350 cubic meters per hour)			
Performance Example (-40°C to 180°C, per IEC 60068 3-5, at supply air)				
*Heating Rate	10°C/m	10°C/m	15°C/m	15°C/m
*Cooling Rate	5°C/m [4°C/m]	9°C/m [8°C/m]	13°C/m [12°C/m]	16°C/m [15°C/m]
Site Requirements				
Electrical Supply	460V 3Ø 60Hz [380-415V 3Ø 50Hz]			
*Recommended Service	45 A [45 A]	45 A [50 A]	60 A [60 A]	70 A [70 A]
Humidity Water	De-ionized water, 0.2 to 10 µS/cm resistivity			
Cooling Water Maximum with 30°C Inlet	9 GPM (35 LPM) (NWL suffix models)	14 GPM (55 LPM) (NWL suffix models)	19 GPM (79 LPM)	27 GPM (106 LPM)
Heat to Room	52,000 BTU/hr (NAL suffix models)	75,000 BTU/hr (NAL suffix models)	—	—

*Cooling capacity, ramp rates, and service amps in brackets are for 380V-415V 50Hz power.

Humidity Control Range

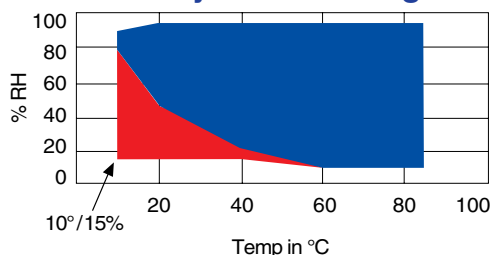

For EGNL & EGNX models:

Blue = Standard humidity range
Red = Optional low-humidity range

Guaranteed humidity control range without live load.
Fluctuation is within $\pm 3\%$, per IEC 60068 3-6.

SPECIFICATION - 35 CU. FT. /1000 L MODELS

RANGE -70 TO 180°C Temp/Humidity

	EGNX35-4NWL EGNX35-4NAL	EGNX35-6NWL EGNX35-6NAL	EGNX35-12NWL	EGNX35-15NW
Temperature Range	-70 to 180°C (-94 to 354°F)			
Cooling Capacity	2.5 kW [2 kW] at -50°C	3.6 kW [3 kW] at -50°C	5 kW [4.2 kW] at -50°C	9.4 kW [7.8 kW] at -50°C
Refrigeration System	Cascade 4 hp Scroll	Cascade 6 hp Scroll	Cascade 12 hp Scroll	Cascade 15 hp Discus
Heating System	10 kW	10 kW	15 kW	20 kW
Humidity Range	10 to 95% RH per chart below			
Measured Airflow	800 CFM (1,350 cubic meters per hour)			
Performance Example (-70°C to 180°C, per IEC 60068 3-5, at supply air)				
Heating Rate	9°C/m	9°C/m	14°C/m	18°C/m
Cooling Rate	3°C/m [2.5°C/m]	6°C/m [5.5°C/m]	13°C/m [11°C/m]	19°C/m [18°C/m]
Site Requirements				
Power Supply	460V 3Ø 60Hz [380-415V 3Ø 50Hz]			
Recommended Service	40 A [45 A]	45 A [50 A]	70 A [70 A]	100 A [100 A]
Humidity Water	De-ionized water, 0.2 to 10 µS/cm resistivity			
Cooling Water Maximum with 30°C Inlet	9 GPM (34 LPM) (NWL suffix models)	14 GPM (55 LPM) (NWL suffix models)	27 GPM (106 LPM)	32 GPM (121 LPM)
Heat to Room	40,000 BTU/hr (NAL suffix models)	60,000 BTU/hr (NAL suffix models)	—	—

*Cooling capacity, ramp rates, and service amps in brackets are for 380V-415V 50Hz power.

RANGE -70 TO 180°C Temp

	EGNZ35-4NWL EGNZ35-4NAL	EGNZ35-6NWL EGNZ35-6NAL	EGNZ35-12NWL	EGNZ35-15NW
Temperature Range	-70 to 180°C (-94 to 354°F)			
Cooling Capacity	2.5 kW [2 kW] at -50°C	3.6 kW [3 kW] at -50°C	5 kW [4.2 kW] at -50°C	9.4 kW [7.8kW] at -50°C
Refrigeration System	Cascade 4 hp Scroll	Cascade 6 hp Scroll	Cascade 12 hp Scroll	Cascade 15 hp Discus
Heating System	10 kW	10 kW	15 kW	20 kW
Measured Airflow	800 CFM (1,350 cubic meters per hour)			
Performance Example (-70°C to 180°C, per IEC 60068 3-5, at supply air)				
Heating Rate	9°C/m [9°C/m]	9°C/m [9°C/m]	14°C/m [14°C/m]	18°C/m [18°C/m]
Cooling Rate	3°C/m [2.5°C/m]	6°C/m [5.5°C/m]	13°C/m [11°C/m]	19°C/m [18°C/m]
Site Requirements				
Power Supply	460V 3Ø 60Hz [380-415V 3Ø 50Hz]			
Recommended Service	40 A [45 A]	45 A [50 A]	70 A [80 A]	100 A [100 A]
Cooling Water Maximum with 30°C Inlet	9 GPM (35 LPM) (NWL suffix models)	14 GPM (55 LPM) (NWL suffix models)	27 GPM (106 LPM)	32 GPM (121 LPM)
Heat to Room	40,000 BTU/hr (NAL suffix models)	60,000 BTU/hr (NAL suffix models)	—	—

*Cooling capacity, ramp rates, and service amps in brackets are for 380V-415V 50Hz power.

DIMENSIONS - 35 cu. ft. models

Workspace Volume	35 cu. ft (1000 L)	
Workspace (WxDxH)	39.4" x 39.4" x 39.4" (1000 x 1000 x 1000 mm)	
Exterior (WxDxH)	NWL suffix models	51" x 93" x 76" (1290 x 2359 x 1920 mm)
	NWL suffix models	51" x 93" x 90" (1290 x 2359 x 2280 mm)
	NAL suffix models	51" x 129" x 79" (1290 x 3274 x 2014 mm)

OPTIONS

Cabinet Options

- Additional adjustable shelves, capacity 45 kg. (100 lbs.)

- Additional cable ports with cover and flexible port plug



50, 100, or 150mm (2", 4", or 6") diameters available

- Viewing window with LED lighting
 - 114 L: 152 x 305 mm (6" x 12")
 - 380 L: 175 x 260mm (7" x 10.5")
 - 470 L: 175 x 260mm (7" x 10.5")
 - 800 L: 290 x 380mm (11.5" x 15")
 - 1000 L: 290 x 380mm (11.5" x 15")

Operational Options

- Attached air-cooled condenser for applications where water-cooling isn't practical. (see page 5)
- Liquid nitrogen (LN₂) cooling boost for faster ramping.
- Dry air purge - Keeps moisture in the chamber extremely low by purging with -40°C dewpoint air. Compressed air supply required.
- Spare parts kit

- Remote environmentally conditioned air (ECA)



Allows conditioning of remotely-located equipment that cannot be placed inside the chamber.

Overall performance and available interior space are reduced.

- Water purifying filter for humidity models
- Low humidity control systems (see chart on previous pages for range)
- Humidity water tank supply

Instrumentation Options

- RS-232 or RS-485 serial interface
- Product temperature control
- Solid state humidity sensor
- Chino paperless recorders with Ethernet
- Solid state humidity sensor in lieu of wet/dry bulb (humidity models)
- Additional time signals for controlling external devices
- Emergency-stop button
- Web Controller for remote Ethernet/web access

Battery Safety Options

Because battery failure is a real risk (and sometimes a desired outcome), environmental chambers need safety systems to protect from harmful explosions and ensure operator safety.

- Spark resistant interior w/ sheathed heaters
- Fenwall Detect-a-fire system, alarms and shuts-down chamber
- Fire suppression system using FM200, CO₂, or Argon
- Product overheat protector
- Gas monitor and alarm (single or two gas, H₂ or CO)
- Chamber ventilation blower and exhaust port
- Pressure-relief blow-out port
- Cable port plug restraint
- Door switch to stop operation if door is opened
- Solenoid-activated pin door lock to prevent opening during operation
- Reinforced door latch, to withstand 1.4 psi pressure
- Product drip tray, in case of battery leak

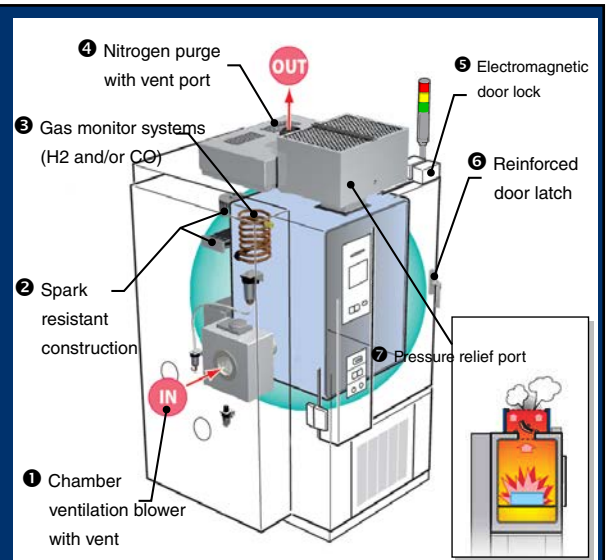

Performance P-300 Programmer/Controller Specification

Display	Color touch-screen, 6.5 inch diagonal, 640x480 resolution Multilingual: English, Japanese, Chinese, Korean, Portuguese
Communications	Standard: USB external memory port Optional: RS-232, RS-485, GP-IB, Ethernet
Operating Modes	STOP: chamber off, programmer on PROGRAM: RUN runs selected test profile CONSTANT: runs at set value continually
Program Capacity	40 programs, 99 steps per program
Control Method	PID (Proportional, Integral, Derivative) plus WRTC (Window Reference Trajectory Control)
Programming Capabilities	<ul style="list-style-type: none"> • Create or copy programs • Upload and download programs via USB • Copy, edit, insert, and delete steps • Two nested loops to repeat steps up to 999 times • Selectable end-of-test modes • Create pause steps within programs • Soak control delays timer until setpoint is reached
Additional Functions	<ul style="list-style-type: none"> • Alarm report lists last 1000 alarms and time occurred • Time signal relay control (with naming capability) • High/low limit alarm functions • Audible alarm with on-screen explanation • Selectable restart modes after power failure • Automatic start and stop functions • Keylock protection and configuration lock-out • Service guide and help screens • Three settable reminder alarms for PM • Integrated running time meter • RoHS directive lead-free compliant



P-300 Remote operation via Ethernet

Ethernet/LAN remote operation is possible via ESPEC's Web Controller. A straight-forward web-browser interface allows remote monitoring, programming and data logging via your local network. Email notice of alarms is also possible.

NEW: The Web Controller allows direct access to P-300 command protocol, bypassing the web interface. Custom programming and integration with other test equipment are now possible via Ethernet.

Learn more and try a live demonstration:

www.espec.com/wc

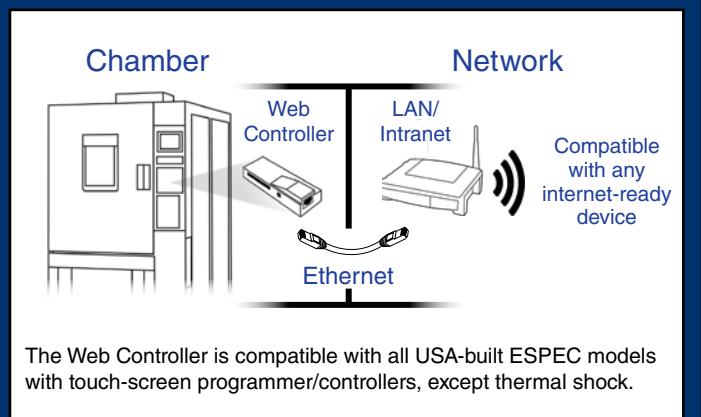

ESPEC NORTH AMERICA, INC.

www.espec.com • sales@espec.com
4141 Central Parkway, Hudsonville, MI 49426, U.S.A.
Tel: 1-616-896-6100

Colorado Office
12600 E. Smith Road, Denver, CO 80011, U.S.A.
Tel: +1 303-254-8800

ESPEC ENVIRONMENTAL EQUIPMENT (SHANGHAI) CO., LTD.

China
www.espec.cn
Tel :86-21-51036677

ESPEC EUROPE GmbH

Germany
www.espec.de • info@espec.de
Tel: 49-89-1893-9630

ESPEC ENGINEERING (THAILAND) CO. LTD.

Thailand
Tel: 66-3-810-9353

ESPEC CORP.

www.espec.co.jp/english
3-5-6, Tenjinbashi, Kita-ku, Osaka 530-8550, Japan
Tel: 81-6-6358-4741



DANGER

Not for use with specimens which are explosive or flammable, or which contain such substances. To do so could be hazardous, as this may lead to fire or an explosion.