



ATS-710E-T THERMOSTREAM®

-80° to +225°C



Advanced Temperature Source for fast and precise thermal conditioning of components, parts, hybrids, modules, subassemblies, and printed circuit boards. Capable of ultra-low temperatures **without** the use of Liquid Nitrogen (LN₂) or Liquid Carbon Dioxide (LCO₂).

PERFORMANCE:

Temperature Range*- No LN₂ or LCO₂ Required

-75 to +225°C (50Hz)

-80 to +225°C (60Hz)

Transition Rate*

-55 to +125°C, approx. 10 seconds or less

125 to -55°C, approx. 10 seconds or less

System Airflow Output*

4 to 18scfm (1.9 to 8.5 l/s) Continuous

TEMPERATURE CONTROL:

Temperature Display & Resolution

+/- 0.1°C

Temperature Accuracy

1.0°C (when calibrated against NIST standard)

DUT Temperature Control

Proprietary control algorithm enables DUT temperature to be directly controlled

DUT Sensor Ports

Internal diode, thermocouples (T & K), RTD (100 Ohm platinum)

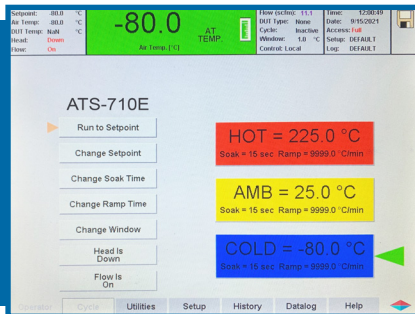

E Series Systems Equipped with Embedded Software Controls, Eliminating Windows® OS

- Significant reduction in security vulnerabilities
- Minimizes software and hardware obsolescence concerns
- Improved responsiveness of the touch screen
- Faster system boot and startup times

FEATURES:

Frost Free Feature

Dry air purge for tester interface, prevents condensation: 0.5 to 3scfm (0.25 to 1.5 l/s)

ECO Friendly Features

- Automatic Power Reduction: reduces power usage during idle periods
- Heat Only Mode: reduces power usage when cold temperatures are not used

Heated Defrost Feature

Quickly removes moisture buildup from internal chiller

Fully Adjustable Thermal Head

- Embedded Control System
- Local & Remote Operations
- On-Screen Help
- Ethernet, IEEE-488, RS232 ports
- USB, keyboard, mouse, & printer ports
- Customizable and savable test setups
- Program & Datalog Storage (via ethernet or USB)
- User Defined Temperature Limits

APPLICATION OPTIONS:

Thermal Cap or FlexExtender Hose

4.5 or 5.5 inch ID Thermal Cap or optional FlexExtender Hose for connection to external Thermal Chambers or enclosures

MobileTemp™ Thermal Chambers

Temperature Chambers designed specifically for uses with ATS THERMOSTREAM® Systems. See Additional Datasheets for details.

**Under nominal operating conditions
Ultimate low temperatures (±1°) achieved at 12scfm*



SYSTEM DIMENSIONS STANDARD

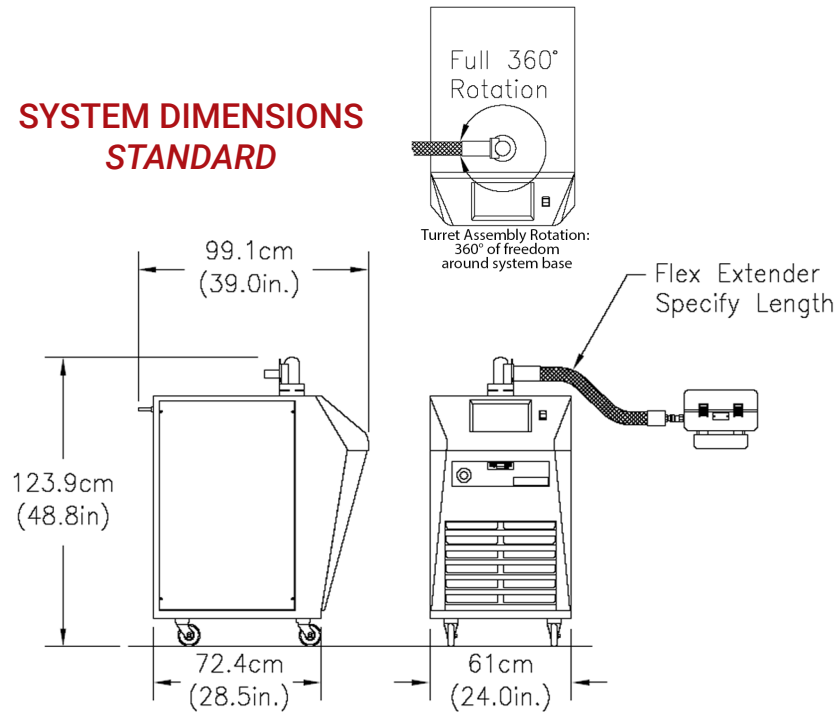

FACILITY REQUIREMENTS

Power ¹	200 - 250 VAC (230V nominal), 50/60Hz, 30 amp, 1phase
COMPRESSED AIR²	
Clean, Dry Air (CDA)	Filtered to 5 micron particulate contamination. Oil Content: <0.1 ppm, by weight, filtered to 0.01 micron oil contaminant. Dewpoint: <10°C @ 6.2 BAR (90PSI)
Air Supply Pressure	6.2 to 7.6 BAR (90 to 110 PSIG)
Total Air Flow Rate Required	7.1 to 14.2 l/s (15-30 scfm), 11.8 l/s (25 scfm) nominal
Air Supply Temperature	+20° to +25°C; +22°C nominal
OPERATING ENVIRONMENT²	
Operating Temperature	+20° to +28°C; +23°C nominal
Humidity	0 to 60%; 45% nominal

WEIGHTS & DIMENSIONS

Base ³	Width: 61.0 cm (24 in.), Depth: 72.4 cm (28.5 in.), Height: 123.9 cm (48.8 in.)
System Weight	Not packed: 226 kg (500 lbs.), Packed: 341 kg (762 lbs.)
Mobility	Four static dissipative, swivel caster wheels
FlexExtender Length	FlexExtender hose available in 1', 2', and 4' standard lengths, custom lengths available
Noise Level	<65dBA

SERVICE & SAFETY

Refrigerants	HCFC and CFC-free, non-toxic, non-flammable
Serviceability	Auto-diagnostics and field replaceable modules
Over Temperature Protection	+230°C (factory set): Operator can set high and low air temperature limits

¹System is configured for operation within voltages listed above using an internal transformer. Please specify power configuration with order

²Under operating conditions which are greater or less than nominal, performance may be less than specification provided

³An additional 20.3cm (8 in.) clearance is required for supply connections and cabinet ventilation

